



eVOQUA
WATER TECHNOLOGIES



PACIFIC OZONE™ PC3 SERIES PORTABLE OZONE WATER SYSTEMS

PORTABLE DISINFECTION FOR SPEED AND FLEXIBILITY

Portable ozonated water production has never been easier or more flexible. The PC3 Series of portable ozone water contacting systems bring together Pacific Ozone's revolutionary air-cooled corona discharge ozone technology in compact and completely integrated ozone contacting systems. These

durable, mobile units provide ozone production comparable to that of permanently installed ozone contacting skids. The PC3 delivers 36 grams per hour, nearly 2 pounds per day.



Model: PC32

COMPLETE, POWERFUL AND MOBILE

Originally developed for the wine industry, the PC3 Series performs tank sanitization, barrel washing, surface disinfection, and clean-in-place (CIP) of tanks and piping. Portable ozone disinfection

with the PC3 Series is ideal for sanitizing surfaces in food and beverage applications including dairy, brewing, fresh cut produce, seafood, processed foods, and meat and poultry. The mobility of the PC3 Series provides dissolved ozone wherever it is needed – at various sites within a single facility, or even at multiple locations for diverse on-site applications.

Features

- All Stainless Steel Construction
- Onboard Air Compressor
- Onboard Oxygen Concentrator
- Onboard Side Stream Injector
- Onboard Injector Pump
- Air-Cooled Ozone Reactor Cell
- Over-Temperature Protection
- Ozone Output Control
- Mixing Tower and Off-Gas Destruct

Benefits

- Easy and Quick to Use
- Rugged Design
- Designed for Safety
- Dissolved Ozone Water On-demand
- Visual Ozone Output Indicator
- Simple Use and Control
- Automatic Water Flow Switch
- Ideal for Supplementing Existing Sanitizing Processes

**SIMPLE. PROVEN.
OZONE TECHNOLOGY.**

OPERATIONAL REQUIREMENTS

All PC3 Series models have the following operational requirements:

- Electrical Requirement: 120/240V, 50/60Hz, 1 phase
20A circuit 120V models, 10A circuit 240V models
- Water Flow Range: 4-30 gpm (15-189 lpm)
- Water Pressure Range: 5-30 psi (1.4-2.1 bar)
- Dissolved Ozone Concentration: Performance varies by condition, see general performance chart
- Use Ozone SAM Test Kit to measure dissolved ozone

PC3 GENERAL DISSOLVED OZONE PERFORMANCE

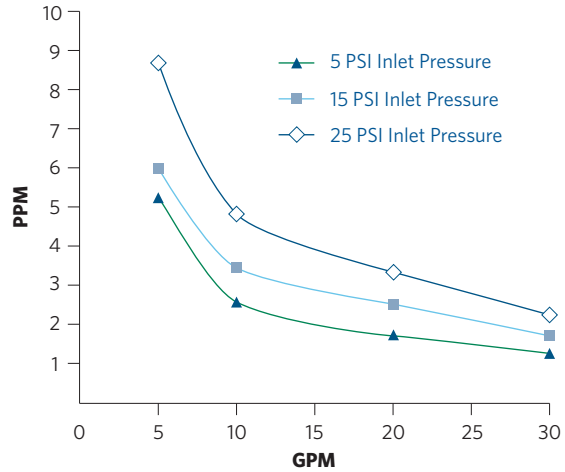

TECHNICAL SPECIFICATIONS

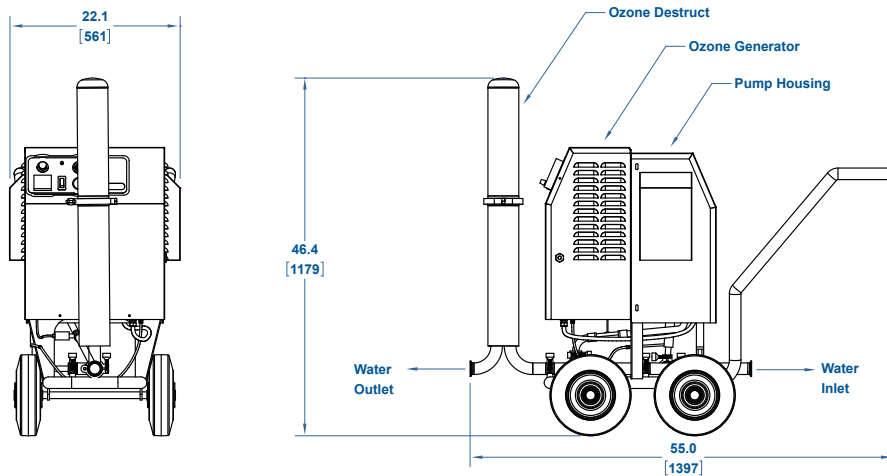

Ozone SAM Test Kit



Hose and Spray Nozzle

(Accessories available at pacificozone.com)

Model	Max. Ozone Production	Max. Ozone Concentration	Max. Reactor Pressure	Feed Gas Flow Range	Water Inlet & Outlet Fittings	Air Cooling	Power Requirement	Dimensions (HxWxD)	Weight
	lbs./day (grams/hour)	% weight	psig (bar)	scfh (lpm)	inches (mm)	cfm (lpm)	volt/amp frequency (Hz)	inches (mm)	lbs (kg)
PC3201	1.9 (36)	8%	12 (0.8)	7-15 (3.3-7.1)	1.5" (38.1) Sanitary Fitting	240 (6796)	120V/20A 60Hz	46.4x22.1x55.0 (1179x561x1397)	215 (98)
PC3202	1.9 (36)	8%	12 (0.8)	7-15 (3.3-7.1)	1.5" (38.1) Sanitary Fitting	240 (6796)	240/10A 50/60Hz	46.4x22.1x55.0 (1179x561x1397)	215 (98)

NOTES:

Complete specifications are provided in the product manual.
Contact your Evoqua sales representative for more information.



6160 Egret Court, Benicia, CA 94510

+1 (707) 747-9600 www.evoqua.com

Trademark statement

All information presented herein is believed reliable and in accordance with accepted engineering practices. Evoqua makes no warranties as to the completeness of this information. Users are responsible for evaluating individual product suitability for specific applications. Evoqua assumes no liability whatsoever for any special, indirect or consequential damages arising from the sale, resale or misuse of its products.